

hanskonner®

hanskonner®

HAG9125SB

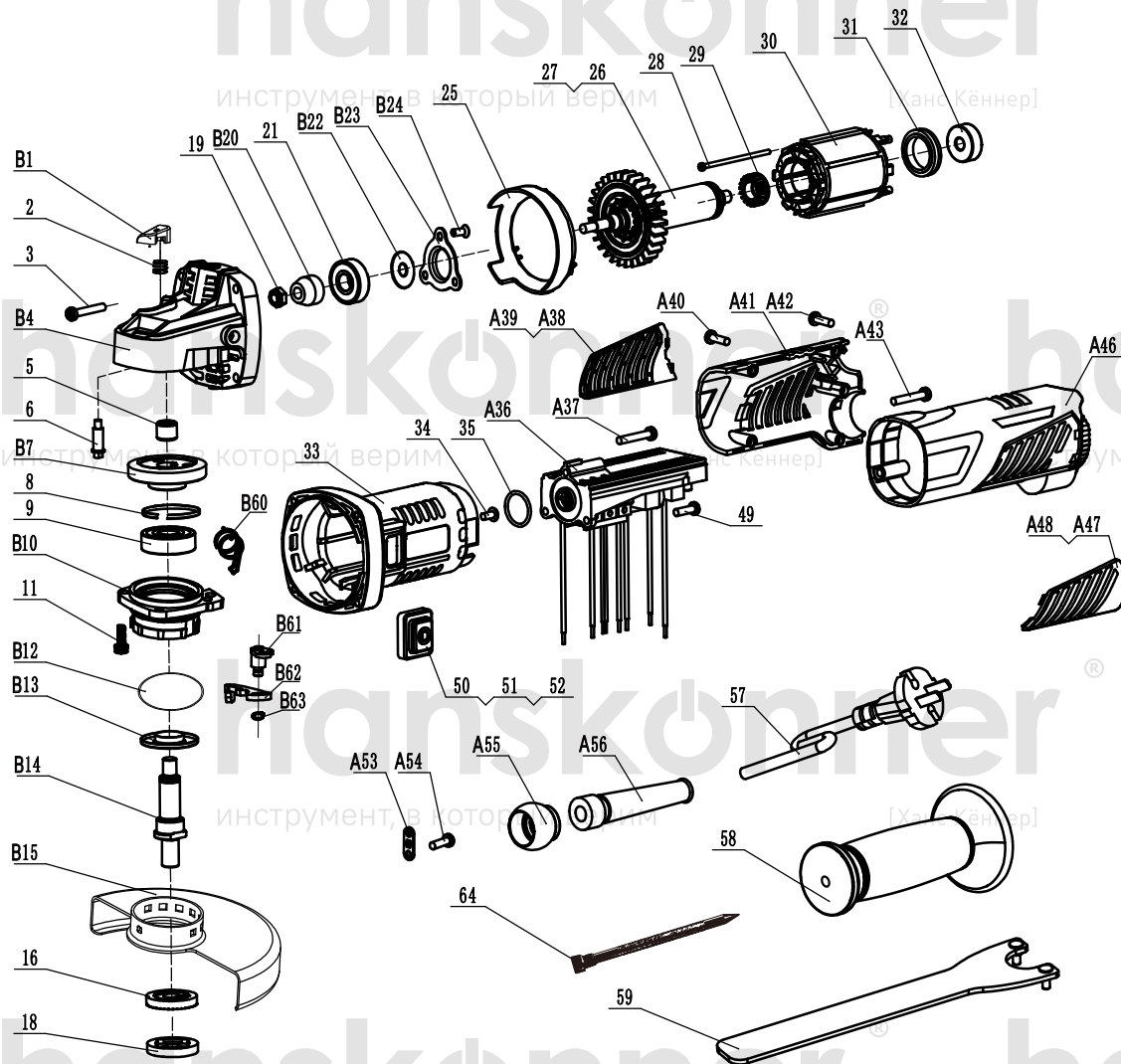

NO.	DESCRIPTION	NO.	DESCRIPTION
B1	LOCKING BUTTON	32	BEARING 608
2	SPRING	33	HOUSING
3	SCREW ST4X25	34	SCREW M4X10
B4	GEAR BOX	35	O RING
5	BEARING 696	A36	CONTROL PCB
6	SPINDLE LOCKING PIN	A37	SCREW ST4X60
B7	BIG GEAR	A38	RIGHT DUST COVER
8	CIRCLIP 32	A39	STEEL NET
9	BEARING 6201	A40	SCREWST3X14
B10	FRONT COVER	A41	REAR HANDLE COVER
11	SCREW M4X14	A42	SCREW ST3X12
B12	O RING Ø42X2	A43	SCREW ST4X30
B13	DUST COVER	A46	REAR HANDLE
B14	SPINDLE	A47	STEEL NET
B15	GUARD	A48	LEFT DUST COVER
16	DOWN FLANGE	49	SCREW ST4X12
18	UPPER FLANGE	50	SWITCH PCB
19	NUT M6	51	SWITCH
B20	PINION	52	SWITCH BRACKET
21	BEARING 629	A53	CABLE PRESS BOARD
B22	WASHER	A54	SCREW ST4X10
B23	BEARING PRESS BOARD	A55	BALL HEAD
B24	SCREW M4X10	A56	CABLE SLEEVE
25	WIND GUIDE	57	CABLE
26	ROTOR	58	AUXILIARY HANDLE
27	FAN	59	WRENCH
28	SCREW ST2.5X55	B60	SPRING
29	SMALL FAN	B61	SUPPORT BLOCK
30	STATOR	B62	LOCKING BLOCK
31	ANTI-DUST RING	B63	CIRCIIP 4
		64	SCRIBER

HAG9125SB-EX-RU250917-1 VER 3,1

инструмент, в который верим

[Ханс Кённер]

инструмент, в который верим

[Ханс Кённер]